

Contents

Introduction	2
About this Document	3
Installing and Replacing SubliJet IQ™ Cartridges	4
Using PowerDriver IQ™	11
Heat Transfer Instructions	12
Tips for Successful Sublimation	13
Troubleshooting Tips for SubliJet IQ	16
Supplies & Equipment	19
Storage	19
Technical Support	20

Introduction

Congratulations on your purchase of SubliJet IQ™ digital transfer inks. The SubliJet IQ sublimation ink cartridges are the latest advance from Sawgrass Technologies, Inc., the leader in the development of digitally driven color transfer technologies and related products.

You can transfer your printed output onto any product designed to accept sublimation dyes including ceramic, metal, mylar, polyester fabric, UniSub, FR plastic, Hanes Soft L'ink shirts and many others. Your transfer will result in an image that is attractive and durable. SubliJet IQ is ideal for markets that personalize, customize or create short-run output. This unique process offers a brilliant near photo-quality image on caps, clipboards, clocks, mugs, mousepads, plaques, puzzles, synthetic T-shirts, and more.

This document contains information for using SubliJet IQ inks and helpful tips are provided for getting the best results from your transfers. The information provided pertains only to the use of SubliJet IQ in your EPSON Stylus PRO 4000 ink jet printer. If you have questions about the operation of your EPSON printer, refer to the *EPSON Stylus PRO 4000 Printer Basics User Guide* for your printer.

SubliJet is bundled with PowerDriver IQ™, an advanced color matching software program that adjusts colors automatically for sublimation printing. Instructions for installation and use of PowerDriver IQ can be found in your *PowerDriver IQ Users Guide*.

Technical support is available from your Authorized SubliJet Reseller or directly from Sawgrass Technologies, Inc. See the section entitled *Technical Support* for additional information.

The team at Sawgrass strives to provide you with the tools to make the sublimation process easy to learn and simple to master. We hope that you will find that the tools we have developed make your years in the sublimation business fun and profitable. Please feel free to contact us with your feedback about our products. For additional information on SubliJet and our other products, visit our website at www.sublimation.com.

Thank you and enjoy your SubliJet IQ printing system.

About this Document

This document contains descriptions and procedures for setting up the Epson 4000 printer using SubliJet IQ inks. Information for getting the best results from your transfers is also included. The information provided pertains only to the use of SubliJet IQ in your EPSON Stylus PRO 4000 ink jet printer and therefore references are made back to the *EPSON Stylus PRO 4000 Printer Basics Guide*.

To help point out important information, specific instructions and helpful tips look for the following symbols:



Indicates **Must-Do** items; including warnings and important guidelines. These must be followed to prevent damage to your printer.



Indicates useful tips for printing and for sublimation.

Installing and Replacing SubliJet IQ™ Cartridges

Installing SubliJet IQ Cartridges

1. Press the Power button to turn on the printer.
2. Open the ink compartment covers by pressing the door to release the latch.

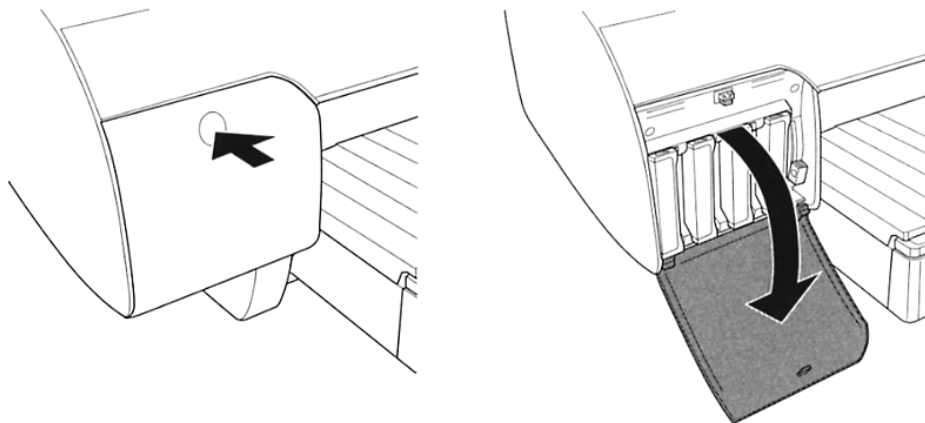

3. Raise both ink levers. These are located on the right side of each ink cartridge compartment.

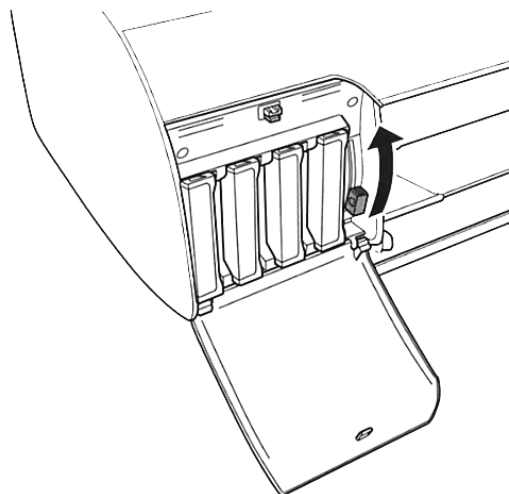

4. Install the ink cartridges into the color-coded slots. When installing the dual sets of ink, the color order of both compartments is K, C, M, Y. The cartridge label should be facing left as the cartridge is inserted into it's slot.

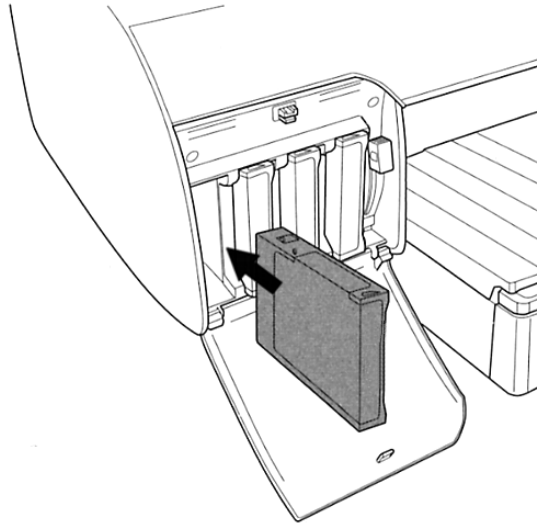

Ensure the cartridges are inserted into the correct color slot before continuing.

5. After all 8 cartridges are installed, lower both ink levers. The printer will begin charging the ink-delivery system and the "pause" light will flash.

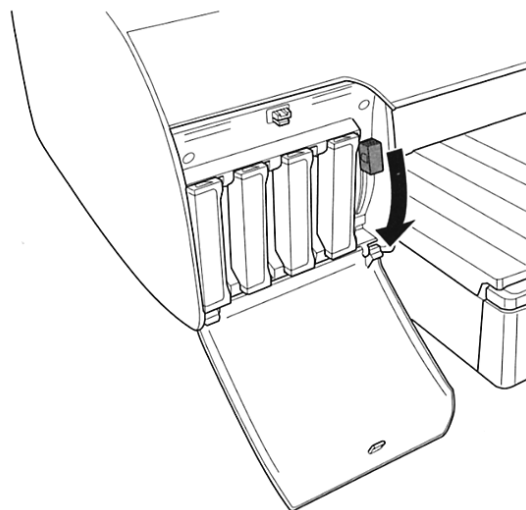

6. After approximately 2 minutes, ink level messages will appear on the LCD. Follow the LCD prompts to raise or lower ink levers.
7. Charging is complete when READY appears on the LCD screen. If using the standard size cartridges, close the ink compartment doors. If using the extended cartridges, the doors will remain open.

Replacing SubliJet IQ Cartridges

When an cartridge is low or empty, INK LOW or INK OUT will display on the LCD panel. The ink indicator - 8 bars which represent the 8 cartridges on the LCD Panel - will flash indicating which cartridge is low or empty. Ensure you have the correct color cartridge for replacement.

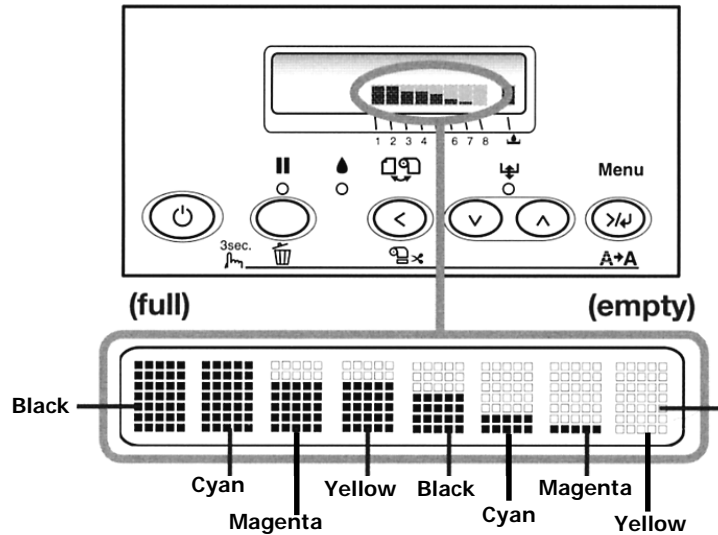

1. Ensure the power is on. Press the ink compartment cover to release the latch and open the cover.

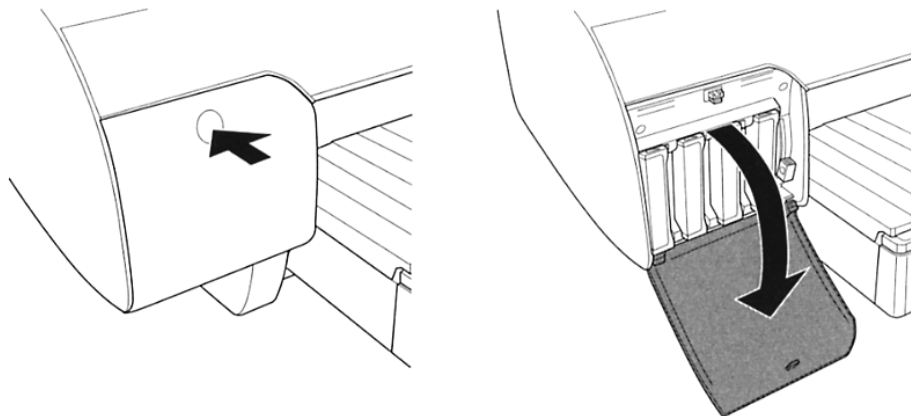

2. Raise the ink lever into the unlocked position. An ink lever is located to the right of each ink compartment.

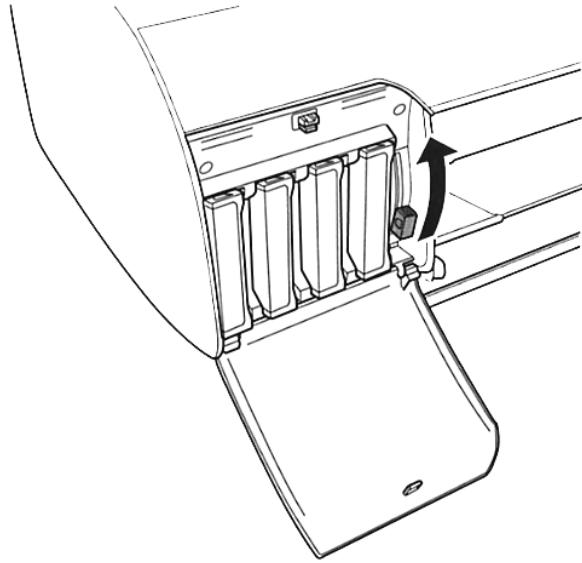

3. Remove the empty ink cartridge from the printer.

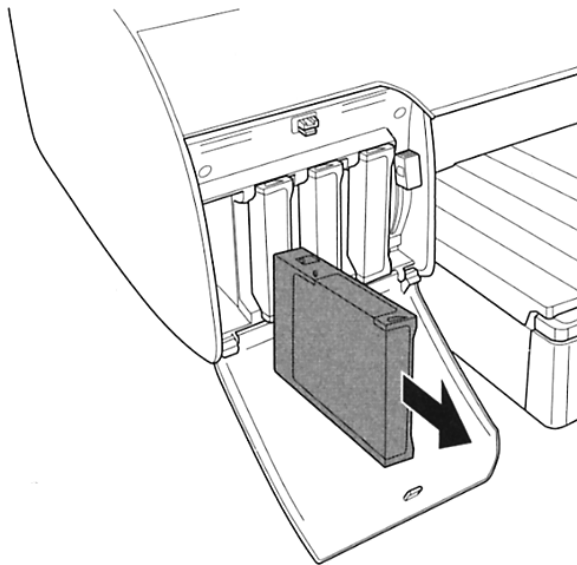

4. Remove the replacement ink cartridge from its packaging and insert it into the slot with the label facing left. Do not force the cartridge into the slot.

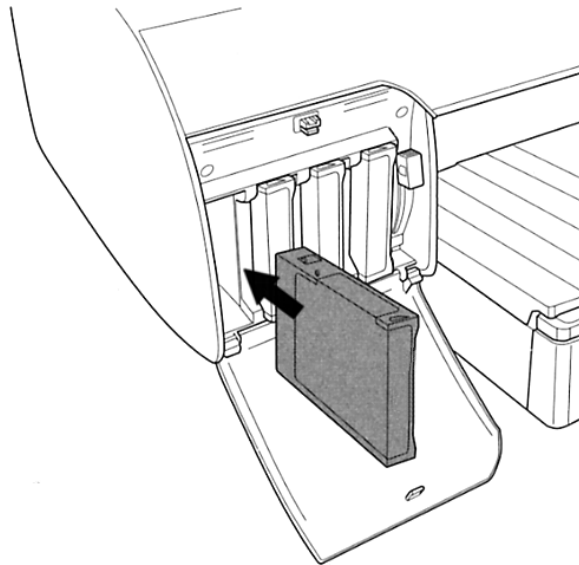

If the cartridge does not insert smoothly into the slot, you may have the wrong cartridge installed. If the ink light remains on after installing the cartridge, remove the cartridge and reinsert it as the cartridge may not be fully inserted.

5. Lower the ink lever in to the locked position.

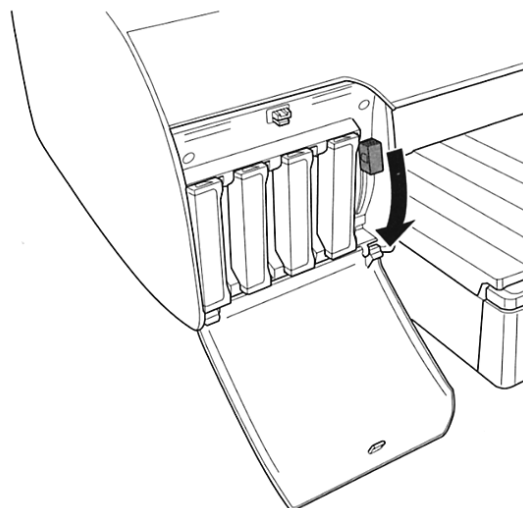

6. Close the ink compartment cover if you have standard size ink cartridges installed. If you have extended cartridges installed in the printer, the cover will remain open.
7. Once the cartridge is installed the printer will return to its READY state.

Selecting Paper

For information on selecting the appropriate paper to use with your SubliJet IQ inks, please check our website at www.sublimation.com or call your Authorized SubliJet Reseller. While the use of copy paper or other ink jet paper will not harm your printer, the transferred results may be light, splotchy or uneven and some papers may stick to the surface or leave a visible residue.

Using PowerDriver IQ

SubliJet IQ digital printing systems are comprised of a few key elements to ensure high quality output each time you print with SubliJet IQ. PowerDriver IQ color management software is one of those tools.

PowerDriver IQ color management software is a professional grade color management program that provides SubliJet IQ users with the necessary tools to ensure colors print right the first time. PowerDriver IQ software is available for all major Windows based operating systems. PowerDriver IQ Color Sync profiles are also available for certain Macintosh based graphics programs.

PowerDriver IQ software and profiles are intended to give you simple, easy to use color management tools to take the guesswork out of sublimation printing. With the click of your mouse you can automatically optimize colors for popular substrates like Unisub™, Soft L'ink™, ceramics, metal and many others. This is a valuable tool that saves you time, money and limits your need for costly sampling trying to get the job right.

PowerDriver IQ also comes standard with the ColorSure Palette Matching system. ColorSure is the best way to match spot colors for corporate logos, specific customer requests and makes designing custom artwork easy. ColorSure is a simple system to use, for instructions on how to use the ColorSure system please refer to the *PowerDriver IQ Users Guide*.

Heat Transfer Instructions

Because you can print on a variety of surfaces, you need to take all variables of the surface into account when selecting time, temperature and pressure. Some of the variables are:

- ◆ thickness of surface
- ◆ how fast the surface absorbs heat
- ◆ coatings used on the material to create a receptive surface for sublimation inks (ceramics, metals, etc.)
- ◆ accuracy of heat press (time, temperature, and pressure)

The time, temperature and pressure listed below are only guidelines. Check with your supplier for specific heat transfer instructions.

Due to the differences in heat presses and the various materials you will be printing on, it is not possible to give absolute figures. You should experiment to find your own preferred settings.

SURFACE	TRANSFER TIME SUBLIJET IQ	TEMP	PRESSURE	REMARKS
POLYESTER/ MOUSEPADS	45 seconds	400°F	40 psi	
METAL (Universal Woods)	60 seconds	400°F	40 psi	Use absorbent, remove plastic
METAL (Other) White, Silver, Gold	60 seconds	375°F - 400°F	40 psi	Time varies with metal manufacturer (<i>Contact your reseller for correct time and temperature</i>) Place absorbent sheet on bottom plate of heat press. Then place transfer paper face up on top of the absorbent. Next place substrate face down on top of the transfer paper. <i>Remove paper from substrate immediately after transferring for best results.</i>
UNISUB	75-85 seconds	400°F	40 psi	Remove Plastic
FR PLASTIC	75-80 seconds	400°F	40 psi	Remove Plastic
SOFT L'INK	35 seconds	400°F	40 psi	Press for 5 secs to eliminate moisture, use Teflon sheet between sides of shirt to prevent "blow through"
CERAMIC	150-210 seconds	350-400°F	40 psi	Time varies with press, use green tile mat for ceramic tile



Tips for Successful Sublimation

Tips for Polyester Fabric

◆ **Use appropriate heat press times.**

- Shortened pressing time may result in good surface color but the sublimation dyes will not completely penetrate the polyester fibers. This leaves the dyes more susceptible to wash out.
- Longer pressing times can cause the dye molecules to penetrate deeper into the fiber, creating a washed out look. For guidelines on transfer times see the section entitled *Heat Transfer Instructions*.

◆ **Use appropriate heat press temperatures**

The correct temperature setting is vital for achieving desired results. Higher temperatures can damage the polyester fibers to the point that they cannot properly “hold” the dyes. For guidelines on transfer temperatures see the section entitled *Heat Transfer Instructions*.

◆ **Use appropriate pressure**

Too much pressure on the heat press may cause the dyes to penetrate too deeply into the fabric causing a washed out look. For guidelines on transfer pressure see the section entitled *Heat Transfer Instructions*.

Tips for Metal

To obtain the best results when printing onto metal, place the transfer between the metal and an absorbent cloth or fresh, non-textured paper towel. This will absorb any dyes that pass back through the paper and any moisture released during the transfer process. If you have problems with inconsistently filled areas, this may alleviate the problem.

Tips for Ceramic Tiles and Mugs

When transferring onto ceramic tiles and mugs, immediately peel the paper off of the ceramic after removing it from the heat press. Once the paper has been removed, cool the ceramic by submerging it in cool water, or run water over it from a faucet. If paper residue remains on the surface of the ceramic, clean with cotton pad and oil based orange cleaner. If you experience a significant paper-sticking problem, call your SubliJet reseller for assistance.

Tips for Hanes Soft L'ink Shirts

- ◆ The presence of moisture in your fabric can lead to bleeding of the image. Remove moisture by pre-pressing your shirt for 10 seconds.
- ◆ Use Teflon sheets between the front and back of the shirt to prevent the inks from penetrating to the other side of the shirt.
- ◆ If dye residue from your heat press is being deposited on your shirts at any time, heat press a paper towel or similar absorbent material to remove residual dye.
- ◆ Before transferring, use a lint roller to remove any debris from the shirt.

Moisture and Humidity Problems

The addition of moisture to the sublimation process can cause unwanted Results. Under normal circumstances, the small amount of

moisture that can accumulate in your paper is absorbed directly into the transfer substrate; however hard substrates like metal and ceramic are unable to absorb excess moisture. Some problems attributed to moisture include; color shifting, bleeding of the image and uneven transfer of solid filled areas.

To avoid these problems

- ◆ Keep the paper in a dry place.
- ◆ If you suspect moisture, set the paper on your press for a few seconds. Do not press it, just expose it to the warmth. The heat radiating from the press should help evaporate most of the moisture.
- ◆ To eliminate moisture in fabric, press the fabric for 10 seconds before transferring an image.
- ◆ Use an absorbent cloth or fresh, non-textured paper towel behind the transfer sheet to absorb the moisture.



Troubleshooting Tips for SubliJet IQ

The troubleshooting tips found in this section relate mainly to problems that can be seen in transferred SubliJet IQ images. If you are having problems related to the performance of your printer, please refer to the *Solving Problems* section of the *EPSON Stylus 4000 PRO Printer Guide*.

The colors in my transferred image are incorrect

- ◆ Color management may not be properly applied. Be certain to use the color matching software you received with your SubliJet IQ cartridges.
- ◆ Ensure you are pressing the item with the proper time, temperature and pressure. See the section entitled *Heat Transfer Instructions* for additional information.
- ◆ Verify that all colors are printing correctly. Run the Nozzle Check utility and clean the print heads as required.
- ◆ If you have done all of the above correctly and you are trying to match a spot color, use the ColorSure color-matching feature available within PowerDriver IQ. See your *PowerDriver IQ Users Guide* for additional information.

My printout is really light on paper

This should be no cause for alarm. SubliJet IQ naturally looks muted before transferring the image. After you heat transfer the image SubliJet IQ's unique inks produce a brilliant and durable final product.

My printout gets cut off on the bottom or side

Verify that your printer driver is setup for the correct paper size. Your printer driver setting needs to match the paper size that is loaded in the printer.

My image looks good but it washes out

- ◆ Ensure you are pressing the garment with the proper time, temperature and pressure. If so, try pressing longer to ensure that the dyes are penetrating the fibers sufficiently.
- ◆ Ensure you are using a recommended paper. See the section entitled *Selecting Paper*.
- ◆ Ensure your substrate is designed to accept sublimation transfers. Garments made from natural fibers such as Cotton, are not compatible with the sublimation process.

Colors are light and plotchy

- ◆ Ensure you are printing on the correct side of your paper. See the section entitled *Selecting Paper*.
- ◆ Ensure you are pressing the item with the proper time, temperature and pressure. See the section entitled *Heat Transfer Instructions* for additional information.
- ◆ Check that you are using the recommended paper. See the section entitled *Selecting Paper*.
- ◆ Ensure you do not have a moisture problem. See the section entitled *Moisture and Humidity*.
- ◆ Ensure your substrate is designed to accept a sublimation transfer.

My image looks blurred

- ◆ Ensure you are pressing the item with the proper time, temperature and pressure. See the section entitled *Heat Transfer Instructions* for additional information.
- ◆ Ensure that you are using a recommended paper. See the section entitled *Selecting Paper*.
- ◆ Ensure you are printing on the correct side of your paper. See the section entitled *Selecting Paper*.
- ◆ Ensure you do not have a moisture problem. Try drying the paper on the press or putting a paper towel behind the transfer when you heat press it. See the section entitled *Moisture and Humidity*.
- ◆ Verify that the printer's print heads are properly aligned. See the section entitled *Aligning the Print Head* in the *EPSON Stylus 4000 PRO Printer Guide*.for more details and instructions.

My image has gaps or bands

- ◆ Ensure that all of your printer's nozzles are firing properly. Perform a nozzle check from the Utility tab of your printer driver. If necessary, perform a cleaning cycle to restore print quality. For more information on performing a nozzle check, see the *EPSON Stylus 4000 PRO Printer Guide*.
- ◆ Verify that the printer's print heads are properly aligned. See the section entitled *Aligning the Print Head* in the *EPSON Stylus 4000 PRO Printer Guide*.for more details and instructions.

Supplies & Equipment

Contact your reseller to purchase sublimation supplies and equipment. For more information, see our Supplies list at www.sublimation.com.

Operating Conditions

Certain environmental conditions should be taken into account for the operation of SubliJet IQ inks, including temperature and relative humidity.

- ◆ Supported Operating Conditions are 65° – 80° F with 40 – 60% relative humidity
- ◆ Optimum Operating Conditions are 68° – 75° F with 40 – 60% relative humidity

Storage

- ◆ Care should be taken to prevent storing SubliJet IQ below freezing temperatures (32°F, 0°C). Do not expose SubliJet IQ to extreme heat (temperatures in excess of 104°F, 40°C). If SubliJet IQ has been in storage, you should allow it to reach room temperature before using it.
- ◆ Do not expose SubliJet IQ cartridges directly to light, especially sunlight, for extended periods.
- ◆ For best results, it is recommended that the SubliJet IQ cartridges be installed before the *Install By* date on the cartridge label and be used within six months of installation.

Technical Support

If you are having difficulties achieving good results from your SubliJet IQ inks, you have several support options:

- 1. Telephone:** You may contact your Authorized SubliJet Reseller during their normal hours of operation for assistance. A full listing of Authorized SubliJet Resellers is available at www.sublimation.com. In addition, you may also contact Sawgrass Technical Support at (843) 884-1575 between the hours of 8:00 AM and 5:30 PM Eastern Standard time Monday through Friday.
- 2. Internet:** Visit the **Technical Support** area at www.sublimation.com. The troubleshooting section found here will provide you with solutions to some of the most common problems. You may submit a detailed description of your problem if you need further assistance. We will work with your reseller to provide you with a solution to your printing problems.
- 3. Fax:** You may fax a detailed description of your problem to Sawgrass Technical Support at (843) 849-3847. We will work with your reseller to provide you with a solution to your printing problems.